

# LAARS<sup>®</sup> NEOTHERM<sup>®</sup>

Residential Modulating,  
Condensing Boilers



**PACKED  
WITH FEATURES**

- *95% Efficient*
- *Less than 10ppm NOx*
- *Condensing operation can greatly reduce homeowner fuel costs*



**LAARS<sup>®</sup>**   
**Heating Systems Company**  
A subsidiary of **BRADFORD WHITE<sup>®</sup>** Corporation

# NEOTHERM®

## A NEW GENERATION OF WARMTH

NeoTherm is a direct vent, sealed combustion, condensing boiler boasting 95% efficiency that modulates with a 5 to 1 turndown. Zero clearance to combustibles and the convenient top connections (horizontal or vertical direct vent) make NeoTherm perfect for tight installations. Featuring an ASME stainless steel heat exchanger and NOx emissions lower than 10ppm, NeoTherm is easy to use and easy on the environment. Built standard with the new LAARS Integrated Control System, all controls are contained in one safe, simple, user-friendly device.

Laars Heating Systems is one of the pioneers of hydronic heating, designing and manufacturing state of the art boilers since 1948. Each and every boiler shipped from our Rochester, NH USA facility is fully fired and tested to make sure when it reaches your home it operates as promised. We take pride in our workmanship and we think you will recognize that when you see our products.



## WHY NEOTHERM?

### ENERGY STAR® RATED

ENERGY STAR® Most Efficient rating means the NeoTherm not only surpasses minimum regulations but can be considered one of the best in the industry.



### FLEXIBLE INSTALLATION

Top connections for piping and vent connections results in cleaner looking installations – up to 100' of air intake and exhaust connections allows for flexibility when venting. Compact in size, the NeoTherm is approved for closet installations. It can fit almost anywhere!

### REDUCE GAS BILLS

**Burn fuel at an ultra-high efficiency of 95% AFUE** - This "Annual Fuel Utilization Efficiency" value means that – 95% of the gas burned is outputted as heat for a home!

**By modulating from 20% to 100% of full fire** - Modulation means that the NeoTherm will automatically adjust how much fuel is used to match a home's demand for heat. The NeoTherm will operate at 100% only on the coldest days of the year and will modulate down on cool days, reducing the amount of fuel burnt to heat a home. **A homeowner can save up to 30% compared to old, noisy on-off boilers.**

### ADVANCED, EASY TO USE CONTROLS

Every NeoTherm is equipped with the New Laars Integrated Control System



- **Easy to use push buttons and large customizable backlit display.**
- **Functions are clearly displayed in English, not complicated codes.**
- **Quick setup feature for basic installations**
- **Complete on-screen diagnostics**
- **Onboard test commands to assist installer and service contractors**
- **Outdoor reset feature for fuel savings**
- **Domestic water priority**

**NEOTHERM IS EVERYTHING A MODERN BOILER SHOULD BE...  
EASY-TO-USE, EASY ON THE ENVIRONMENT, POWERFUL AND COMPACT.  
IT'S THE PERFECT CHOICE FOR TODAY'S DEMANDING HOMEOWNER.**

# HOW DOES **NEOTHERM** DO IT?

In older designs, the heat trapped in boiler flue gas would go up the chimney instead of heating your home. Our technology releases the heat stored inside the exiting flue gas to increase efficiency!

- When the flue gas contacts the NeoTherm's stainless steel heat exchanger it begins to condense, releasing stored heat.
- Heat released by condensing is combined with the heat from the burner flame.
- The result is 95% of the available heat is transferred to your home - up to 30% more energy verses older low efficient designs - saving you money!



## DOMESTIC WATER HEATING USING THE NEOTHERM & LAARS-STOR INDIRECT WATER HEATER



Use the high efficiency heat output of the NeoTherm boiler combined with a Laars-Stor indirect tank and save even more money on your domestic water heating as compared to conventional systems.

The ingenious Laars-Stor™ water heaters are engineered to provide the highest hot water output at the lowest pressure drop of most any indirect fired water heater in the industry.



Hot water from the NeoTherm enters the coiled heat exchanger that sits inside the Laars-Stor tank. The heat from the boiler water is efficiently passed through the heat exchanger coil to the domestic water in the tank. The Laars-Stor uses the 95% efficient NeoTherm to do the work! The tank and boiler can be located close to each other resulting in minimal space used.

The Laars-Stor is packed with features to ensure many years of safe, hot water when you need it!

### LAARS-STOR FEATURES INCLUDE:

- Residential Laars-Stor comes in 6 sizes with multiple coil options to match a home's heating requirement
- Heat Exchanger can be Single or Double wall glass coated steel, for improved service life and heat transfer
- Three Protective Anode Rods provides protection against corrosion for long trouble-free service
- 2" Non-CFC foam insulation covers the sides and top of tank to save energy by retarding loss of heat
- Stand-by Heat Loss—Less than 1/2°F per hour
- Factory Installed Sediment Reduction System
- T&P Relief Valve Installed on all models
- Limited lifetime warranty, reference warranty sheet for full details.

*For more information on Laars-Stor please reference the Laars-Stor brochure.*

# LAARS® NEOTHERM® RESIDENTIAL HYDRONIC BOILER



## NEOTHERM FEATURES:

- Floor-standing condensing boiler
- All connections are on top of unit
- Rated for alcove and closet installations
- Easy to service
- Qualifies for many Energy Rebates
- 95% AFUE
- LAARS Integrated Control System<sup>SM</sup>
- Works with Building Automation Systems
- Backlit LCD display with touch pad
- Quick Setup control feature
- Control display in plain English, not cryptic codes

## STANDARD EQUIPMENT:

- High condensing efficiency
- Modulation down to 20% of full fire (5:1 turndown)
- Sealed combustion chamber
- Pre-mix stainless steel burner
- Low NOx system exceeds the most stringent regulations for air quality – 10ppm NOx
- Horizontal or vertical direct vent
- Horizontal vent and air terminals
- Vent and air pipe lengths of up to 100 equivalent feet (each)
- Built-in condensate trap
- Vent temperature cutoff
- Indirect water heater priority (sensor included)
- ASME 30 psi (207 kPa) working pressure heat exchanger
- ASME "H" stamp
- Stainless steel heat exchanger with welded construction (no gaskets)
- 30 psi (207 kPa) ASME rated pressure relief valve
- Temperature and pressure gauge
- Drain valve

- Multiple pump control for boiler, system and indirect domestic water pumps, each with delay
- Optional pump (sized to model) available for field installation
- Electronic PID modulating control
- Direct spark ignition
- Large user-interface and display
- Alarm output
- Accepts external (4- 20mA or 0-10VDC) modulation signal
- Outdoor reset (sensor included)
- On/Off toggle switch
- Manual reset high limit
- Burner site glass
- Flue gas temperature cutoff
- Zero clearance to combustible surfaces
- 12-year limited warranty

	Input	Output	AFUE %
Size	BTU/h	BTU/h	
80	80000	74,000	95.0
105	105000	96,000	95.0
150	150000	138,000	95.0
210	210000	194,000	95.0

Dimensions are nominal and are shown in inches, cm.

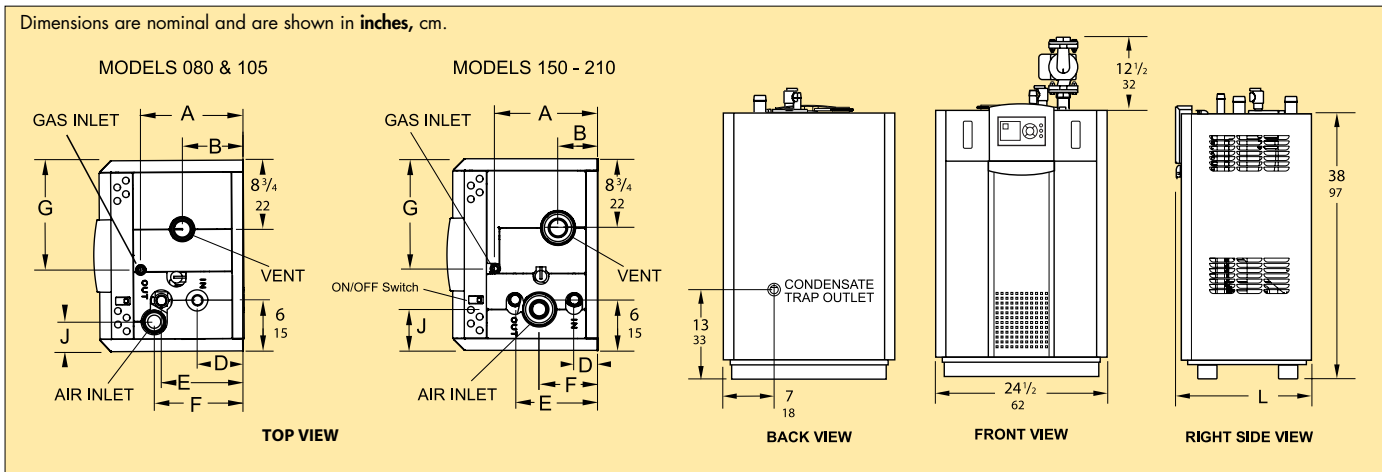

Size	A		B		D		E		F		G		J		L		Air Inlet*		Vent*		Connections		Max Vent Length		Weight lbs.
	in	cm	in	cm	in	cm	in	cm	in	cm	in	cm	in	cm	in	cm	in	cm	Water	Gas	2" Dia.	3" Dia.			
80	13 1/2	34	9 1/2	24	7 1/2	19	10 3/4	28	11 3/4	30	13 3/4	35	3 1/2	9	19 1/2	49	2	5.1	2	5.1	1 NPT	1/2 NPT	40 ft.	100 ft.	202
105	13 1/2	34	8	21	6	16	10 3/4	28	11 3/4	30	14 1/4	36	3 1/2	9	19 1/2	49	2	5.1	2	5.1	1 NPT	1/2 NPT	40 ft.	100 ft.	216
150	13 1/4	34	5 1/4	14	3 1/4	8	10 3/4	28	7 1/2	19	14 1/4	36	5	13	19 1/2	49	3	7.6	3	7.6	1 NPT	1/2 NPT	n/a	100 ft.	228
210	20 1/2	52	5 1/4	14	3 1/4	8	17 3/4	45	7 3/4	19	14 1/4	36	5	13	26 3/4	68	3	7.6	3	7.6	1 NPT	1/2 NPT	n/a	100 ft.	270

\* NeoTherm is shipped with adapters for the air and vent that accept standard pipe of the proper size and type.



800.900.9276 • FAX 800.559.1583 (Customer Service, Service Advisors)  
 20 Industrial Way, Rochester, NH 03867 • 603.335.6300 • FAX 603.335.3355 (Applications Engineering)  
 9 Brigden Gate, Halton Hills, Ontario, L7G 0A3, Canada • 905-203-0600 • FAX: 905.636.0666  
[www.Laars.com](http://www.Laars.com) Litho in U.S.A. © Laars Heating Systems Co. 1805 Doc. 12201